

- B-21, Bhan Nagar, Queens Road, Jaipur-302021
- Website: www.aumshivay.com, www.omengineering.in
- E-mail: admin@aumshivay.com

PIPE WRENCH

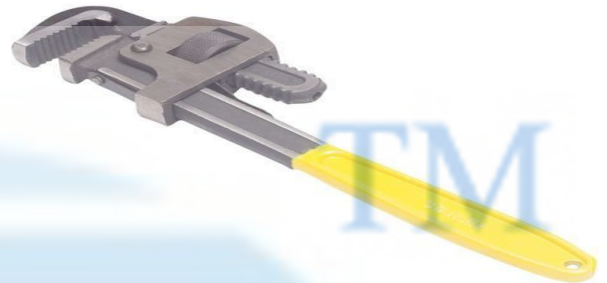

PIPE WRENCH: We deals with Taparia make Heavy Duty Pipe Wrench has drop jaws forged from chrome molybdenum [Cr Mo] steel. It comes with extremely precise machined jaw teeth with appropriate teeth angle of 76° to enables positive grip on the job. Differential hardening of Teeth and Body of the Jaw enables high torque and high wear resistance of the Jaw.

PIPE WRENCH (STILLSON TYPE)

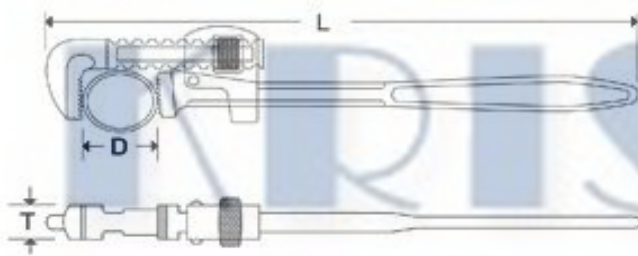

PROD. NO.	D	T	L	WT. GMS
1272	33	15	250	500
1273	42	19	300	750
1274	48	21	350	1000
1275	60	24	450	1540
1276	73	28	600	2920
1277	90	34	900	5880

- B-21, Bhan Nagar, Queens Road, Jaipur-302021
- Website: www.aumshivay.com, www.omengineering.in
- E-mail: admin@aumshivay.com

UNIVERSAL PIPE WRENCH

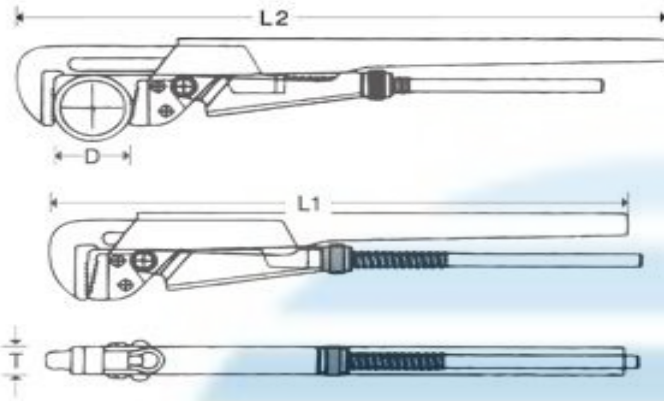

PROD. NO.	DIMENSIONS (MM)				
	A	B	C	D	WT. GMS
1510	38	17	275	310	690
2014	52	21	360	420	1244

HEAVY DUTY PIPE WRENCH

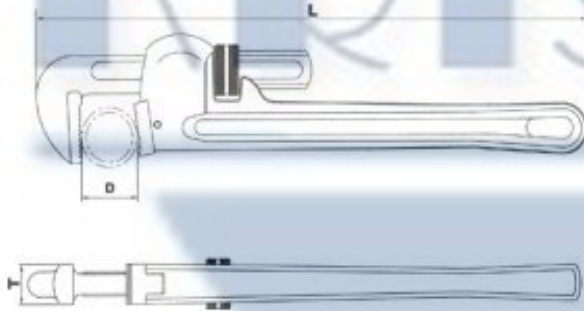

PROD. NO.	DIMENSIONS (MM)			
	NOM. PIPE	T	L	WT. GMS
HPW 08	35	15	200	4200
HPW 18	76	26	450	2400
HPW 10	49	17	250	850
HPW 24	33	26	600	4100
HPW 12	60	23	300	1100
HPW 36	140	37	900	8800
HPW 14	60	23	350	1650
HPW 48	166	37	1200	13800

Drop forged from Chrome Molybdenum (Cr Mo) Steel. Precision machined jaw teeth with appropriate teeth angle enables positive grip on the job. Differential hardening of teeth and body of the jaw enables high torque and wear resistance of the jaw teeth. Handle made from ductile cast iron which enables higher torque values for heavy duty pipe wrenches.

- B-21, Bhan Nagar, Queens Road, Jaipur-302021
- Website: www.aumshivay.com, www.omengineering.in
- E-mail: admin@aumshivay.com

ALUMINUM HANDLE PIPE WRENCH

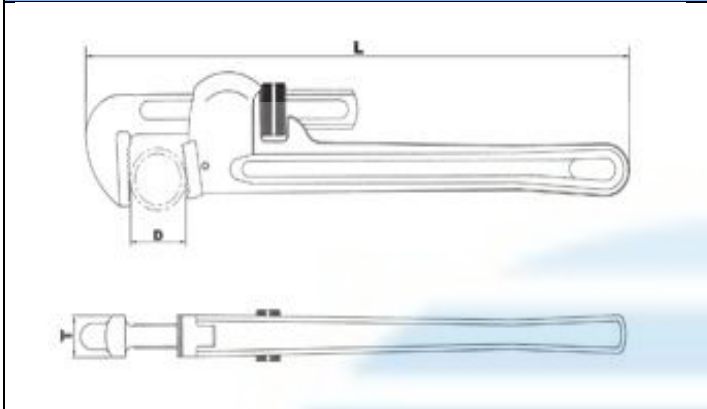

PROD. NO.	DIMENSIONS (MM)			
	NOM. PIPE	T	L	WT. GMS
APW 10	49	17	250	600
APW 24	90	33	600	2500
APW 14	60	23	350	1000
APW 36	140	37	900	4750
APW 18	76	26	450	1500
APW 48	166	37	1200	7700

Drop forged jaws and differential hardened teeth and body of the jaw enables high torque and high wear resistance of the jaw teeth. Precision machined jaw teeth with appropriate teeth angle enables positive grip on the job. Handle made from special grade Aluminium Alloy which reduces the weight of the AL.PIPE WRENCH by upto 40% as compared to respective sizes of heavy duty pipe wrenches.

CHAIN PIPE WRENCH

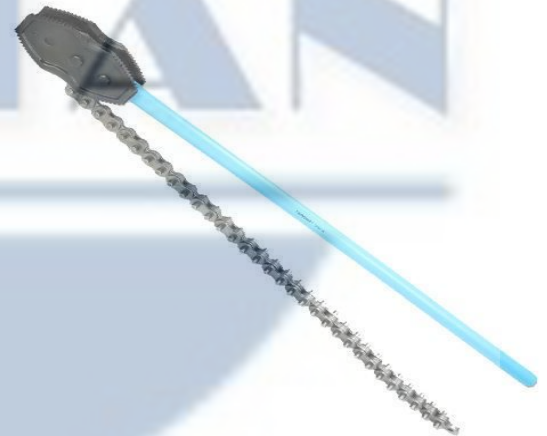
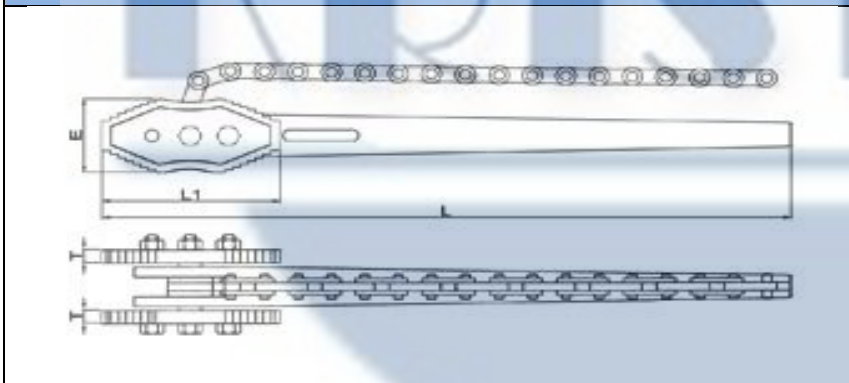

PROD. NO.	NOM. PIPE SIZE MAX ØD	DIMENSIONS (MM)				WT. GMS
		L	L1	E	T	
CPW04	CPW04	900	165	80	12	1100
CPW06	CPW06	1000	180	90	13	9500
CPW08	CPW08	1200	190	90	14	11800
CPW10	CPW10	1300	215	95	15	13500
CPW12	CPW12	1400	215	95	15	14500
CPW16	CPW16	1585	215	95	15	16500

Drop forged jaws with high - grade steel. An accurately machined jaw teeth on both sides of the jaw provides firm gripping and are easy for reverse operation. Scientifically heat - treated to give maximum strength and wear resistance.

- B-21, Bhan Nagar, Queens Road, Jaipur-302021
- Website: www.aumshivay.com, www.omengineering.in
- E-mail: admin@aumshivay.com

SPARES FOR CHAIN PIPE WRENCH

PROD. NO.	NOM. PIPE ØD	DIMENSIONS		
		T	L	WT. GMS
CPW 04 C	-	-	675	-
CPW 06 C	-	-	825	-
CPW 08 C	-	-	975	-
CPW 10 C	-	-	1125	-
CPW 12 C	-	-	1275	-



KRISTAN